

***Hydrolution PRO***

# AIR-SOURCE INVERTER HEAT PUMPS



FROM 50 TO  
100kW

ABOUT 60%  
REDUCTION  
IN GLOBAL  
WARMING  
POTENTIAL

24%  
REDUCTION OF  
REFRIGERANT  
ENTRAPEMENT

## COMPACT & TOP-LEVEL ENERGY

Introducing the Hydrolution Pro - Mitsubishi Heavy Industries' (MHI) Air-source Inverter Heat Pump, featuring an advanced "e-3 D Scroll" Compressor and eco-friendly R32 refrigerant and impressively low Global Warming Potential (GWP).

This innovative system signifies a remarkable advancement in heating and cooling technology, emphasizing enhanced efficiency and environmental sustainability. Its exceptional performance stands out, significantly reducing environmental impact compared to traditional refrigerants.

## WHY R32?

**Efficient Comfort: Air-Source Heat Pumps featuring the 'e-3D Scroll' Compressor and Eco-Friendly R32 refrigerant.**

Mitsubishi Heavy Industries has engineered the innovative Hydrolution Pro heat pump, precisely designed with an exceptional focus on quality and intricate details. Versatile in its capabilities, the Hydrolution Pro caters to a diverse range of applications, covering residential comfort to industrial or IT cooling requirements. The Hydrolution Pro heat pump distinguishes itself by being the most compact while delivering top-tier energy efficiency within its category. Its exceptional performance ensures superior functionality across various applications, maintaining an unparalleled level of compactness.

### BENEFITS OF R32

1. Low Global Warming potential and Superior Energy Efficiency
2. Zero Ozone Depletion
3. Easy to recycle
4. It complies with F-Gas
5. Single component, easy to handle refrigerant
6. Already used in the air conditioning systems and heat pumps worldwide
7. It requires up to 13% less charge compared to R410A

ENERGY  
EFFICIENCY

IMPACT ON  
ENVIRONMENT

COST  
EFFECTIVENESS

R32  
PERFORMANCE

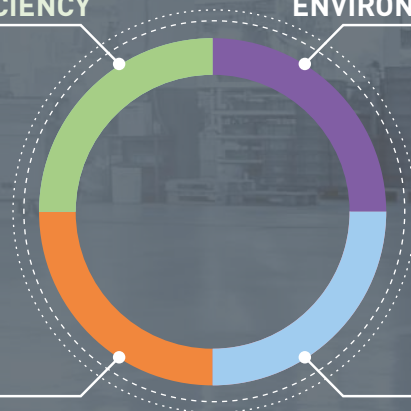



50kW  
**4.59**  
SCOP

50kW  
**3.47**  
COP \*

# HIGH EFFICIENCY

**New Technology “e -3 D Scroll” Compressor Uses EC Fan for Highest Efficiency and Energy Savings.**

- Introducing a world-first compression process design
- Enhancing energy efficiency with outstanding low-speed performance
- Significantly boosting compressor efficiency

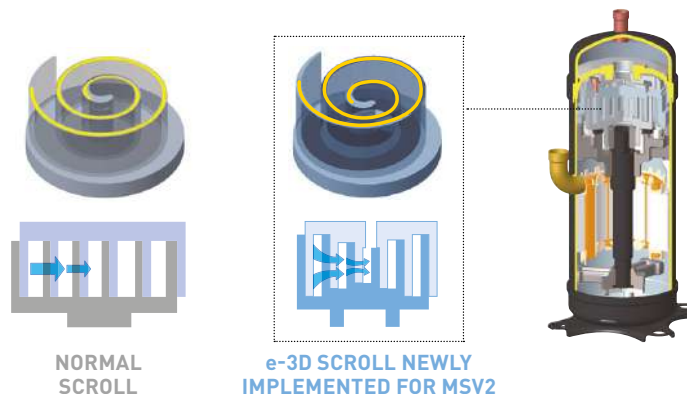

## Applicable to a Wide Range of Applications or Cooling & Heating Operation

- Standard for annual cooling and heating
- Cooling operation under 47°C air inlet

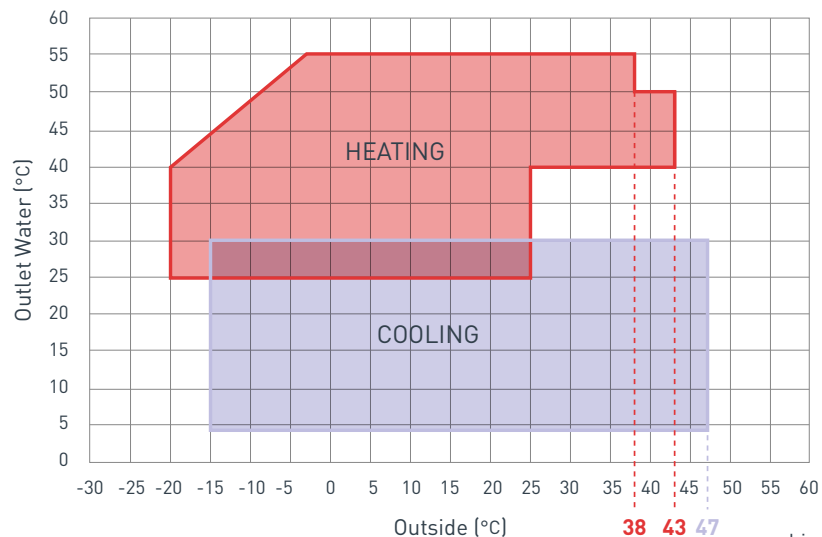

\* SCOP: Seasonal Space Heating Class Average Climate General Water Outlet 35 °C

\* Due to planned change, figures are subject to change.



# SPECIFICATION

		Model	50kW	75kW	100kW
Compressor (inverter scroll)			50kW x 1	75kW x 1	50kW x 2
Cooling Capacity		kW	44.0	75	100
Heating Capacity		kW	47.0	75	100
Power Input	Cooling	kW	15.1	27.2	34.0
	Heating	kW	13.5	25.6	29.9
EER		-	2.91	2.76	2.94
COP		-	3.47	2.93	3.35
SEER		-	4.48	TBD	TBD
"Seasonal Space Heating Class	ns	%	181%	160%	160%
Average Climate General Water Outlet 35°C	SCOP	-	4.59	4.00	4.00
	Class	-	A+++	A++	A++
Dimensions	Height	mm	2,186	2,186	2,186
	Width	mm	1,135	1,135	1,135
	Length	mm	2,209	2,209	2,786
Rated Operation	Cooling	°C	12/7	12/7	12/7
	Heating	°C	40/45	40/45	40/45
Water Flow Minimum - Maximum		m <sup>3</sup> /h	3.0-13.8	4.8-12.9	6.0-17.2
		L/min	50-230	80-215	100-287
Minimum System Water Volume		L	1276 <sup>(1)</sup> /319 <sup>(2)</sup>	1435 <sup>(1)</sup> /359 <sup>(2)</sup>	1276 <sup>(1)</sup> /319 <sup>(2)</sup>
Leaving Water Temperature Range	Cooling	°C	4-30°C	4-30°C	4-30°C
	Heating	°C	25-55°C	25-55°C	25-55°C
Outdoor Air Temperature Range	Cooling	°C	-15-47°C	-15-47°C	-15-47°C
	Heating	°C	-20-43°C	-20-43°C	-20-43°C
Refrigerant	Type		R32	R32	R32
Acoustic Data	Sound Power	dB(A)	86.0dB	87dB	89dB
	Sound Pressure	dB(A)	68.5dB	69dB	70dB
Water pump	Rated output of the motor	kW	LP:0.9/HP:1.8	LP:0.9/HP:1.8	LP:1.5/HP:3.0
	Rated operating current	A	LP:1.2/HP:2.2	LP:1.6/HP:2.7	LP:2.3/HP:3.2
	Rated unit outside head [at 5°C Difference]	m	LP:17/HP:27	LP:14/HP:24	LP:15/HP:22

(1) Minimum allowable temperature difference 0.5 deg. (inlet water temp. and set point) for unit to start running.

(2) Minimum allowable temperature difference 2.0 deg. (inlet water temp. and set point) for unit to start running.

\* SCOP: Seasonal Space Heating Class Average Climate General Water Outlet 35°C

\* COP Conditions: Cond. 40/45°C, air 7(6)°C-NET values [EN14511-EN14825] \* Numbers are subject to change.

## List of models

Heat pump	Standard	50kW	75kW	100kW	
		Pumpless		MCUS5001VHE-W	
				Built-in LP pump	MCUS5001VHE-W1
				Built-in LP pump + Expansion Tank	MCUS5001VHE-W1A
				Built-in HP pump	MCUS5001VHE-W2
				Built-in HP pump + Expansion Tank	MCUS5001VHE-W2A
		Pumpless		MCUS7501VHE-W	
				Built-in LP pump	MCUS7501VHE-W1
				Built-in LP pump + Expansion Tank	MCUS7501VHE-W1A
				Built-in HP pump	MCUS7501VHE-W2
				Built-in HP pump + Expansion Tank	MCUS7501VHE-W2A
		Pumpless		MCUS10001VHE-W	
				Built-in LP pump	MCUS10001VHE-W1
				Built-in LP pump + Expansion Tank	MCUS10001VHE-W1A
				Built-in HP pump	MCUS10001VHE-W2
				Built-in HP pump + Expansion Tank	MCUS10001VHE-W2A

## Unit configuration

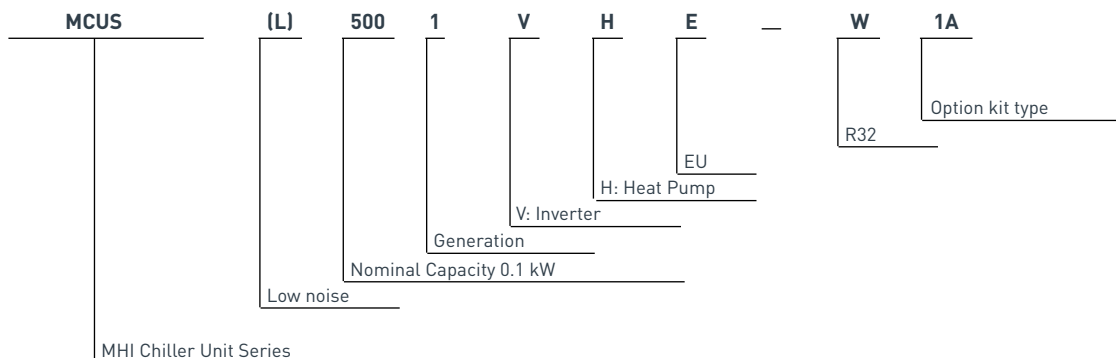



# UNIT & CONTROLLERS



## Unit MCUS55001VHE-W

- Achieving the highest levels of efficiency and energy savings.
- "e -3 D Scroll" Compressor significantly improves energy-saving performance at low speed operation.
- Standard for annual cooling and heating.
- Cooling operation under 47°C air inlet.
- Using low GWP refrigerant - R32.
- Cooling/Heating mix mode control possible.



## Remote control RC-MCU-E

- One remote control (RC-MCU) can be connected to up to 20 MCU tables and operated in a single operation.
- Cooling/Heating mixed mode can be set by a remote controller.
- An annual schedule can be set in six different patterns.
- Capacity and COP can be displayed.
- Memorise settings of cooling/heating temperature separately.
- Enable to check MCU Controller's Error as well as Error reset.

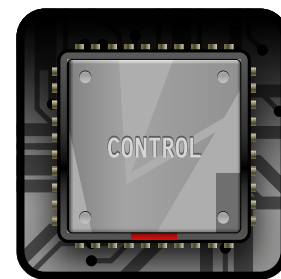

## Advanced Controllers MCU-C-E

- The MCU Controller enables control and leveling operation of 20 units.
- Annual schedule also available via remote control connection.
- Optimally controls the number of vehicles to be operated according to the equipment load.
- Supply pressure is automatically controlled by bypass valve control.
- Cold and hot water pump control to optimize flow rate is not only primary, can be up to secondary pump side.
- The priority is assigned to the MCUS chilling unit, which has less operation time, ensuring the equalization of driving time.

# DIMENSIONS

Model MCUS5001VHE-W

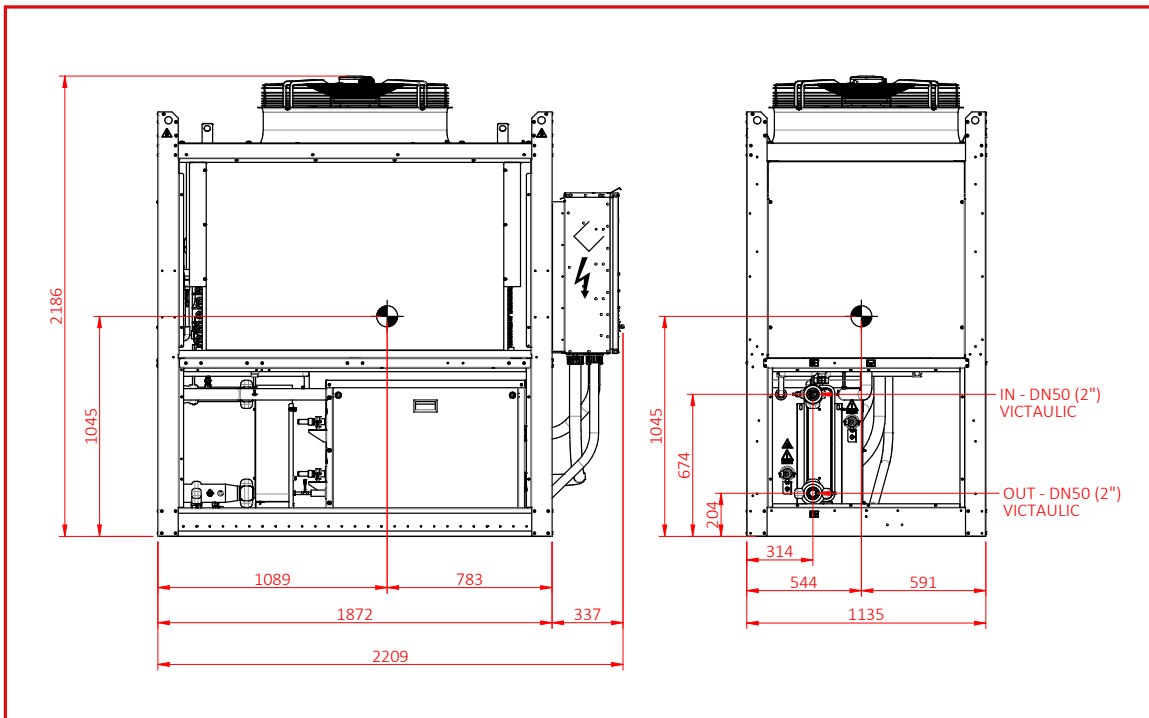

Model MCUS75001VHE-W

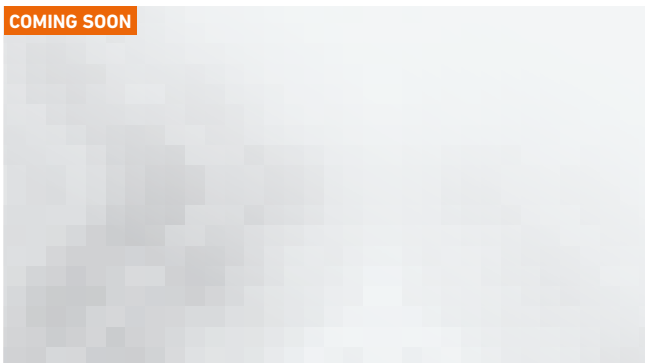

Model MCUS10001VHE-W





**Mitsubishi Heavy Industries Air Conditioning Europe Ltd**  
5 The Square, Stockley Park, Uxbridge, UB11 1ET <http://www.mhiae.com>



MITSUBISHI HEAVY INDUSTRIES-  
MAHAJAK AIR CONDITIONERS CO., LTD.  
Certified ISO 9001  
Certificate Number : 44 100 980813



Certificate Number: YK44019508



MITSUBISHI HEAVY INDUSTRIES-  
MAHAJAK AIR CONDITIONERS CO., LTD.  
Certified ISO 14001  
Certificate Number : 04 104 980813

